

Safety

1. Installation

1.1 IO:Services

1.2 Driver Card Installation

1.3 Current Loop Wiring

2. Configuration - Operation

2.1 Diagnostics

2.2 Manual – Auto

2.3 Hardware Calibration

3. Specifications

Safety

30 VDC maximum on field wiring terminals.

24 VDC maximum on internal card surfaces.

1. Installation

1.1 IO:Services

The IO driver provides one or two, DC isolated, loop powered 4-20mA outputs.
 Up to four dual, 4-20mA output 'IO' drivers may be installed in an M7 or M14 controller for one to eight, 4-20mA outputs.

1.2 Driver Card Installation

1. Enable two current outputs, C1 to C8.
2. Turn OFF the controller AC power
3. IO drivers may be installed in any of the M7 or M14 controller slots. Usually the first IO module is installed in slot 'G' since this M7 single sensor slot supports a dual IO driver.
4. Turn ON the controller after installing the IO Driver and the controller will auto-configure, displaying the assigned current output C1 to C8, on the LCD display and browser.

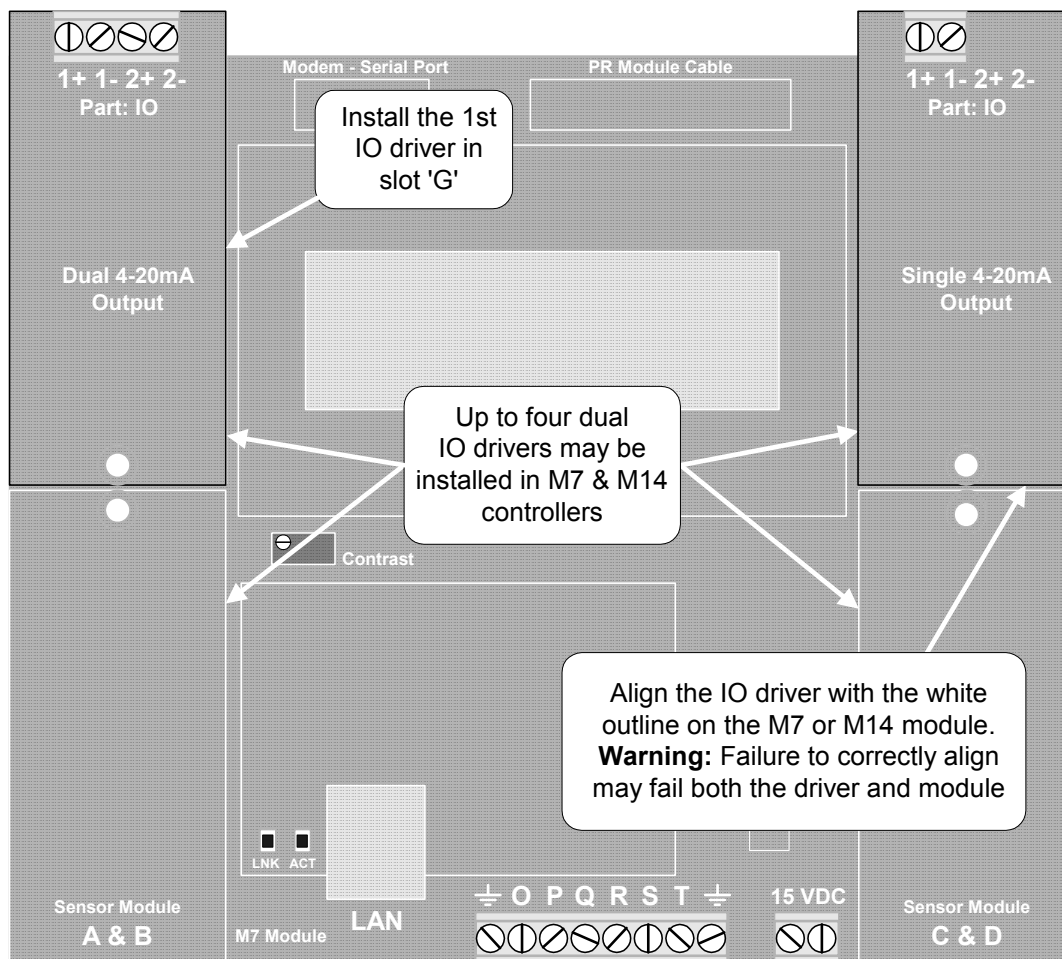

1.3 Current Loop Wiring

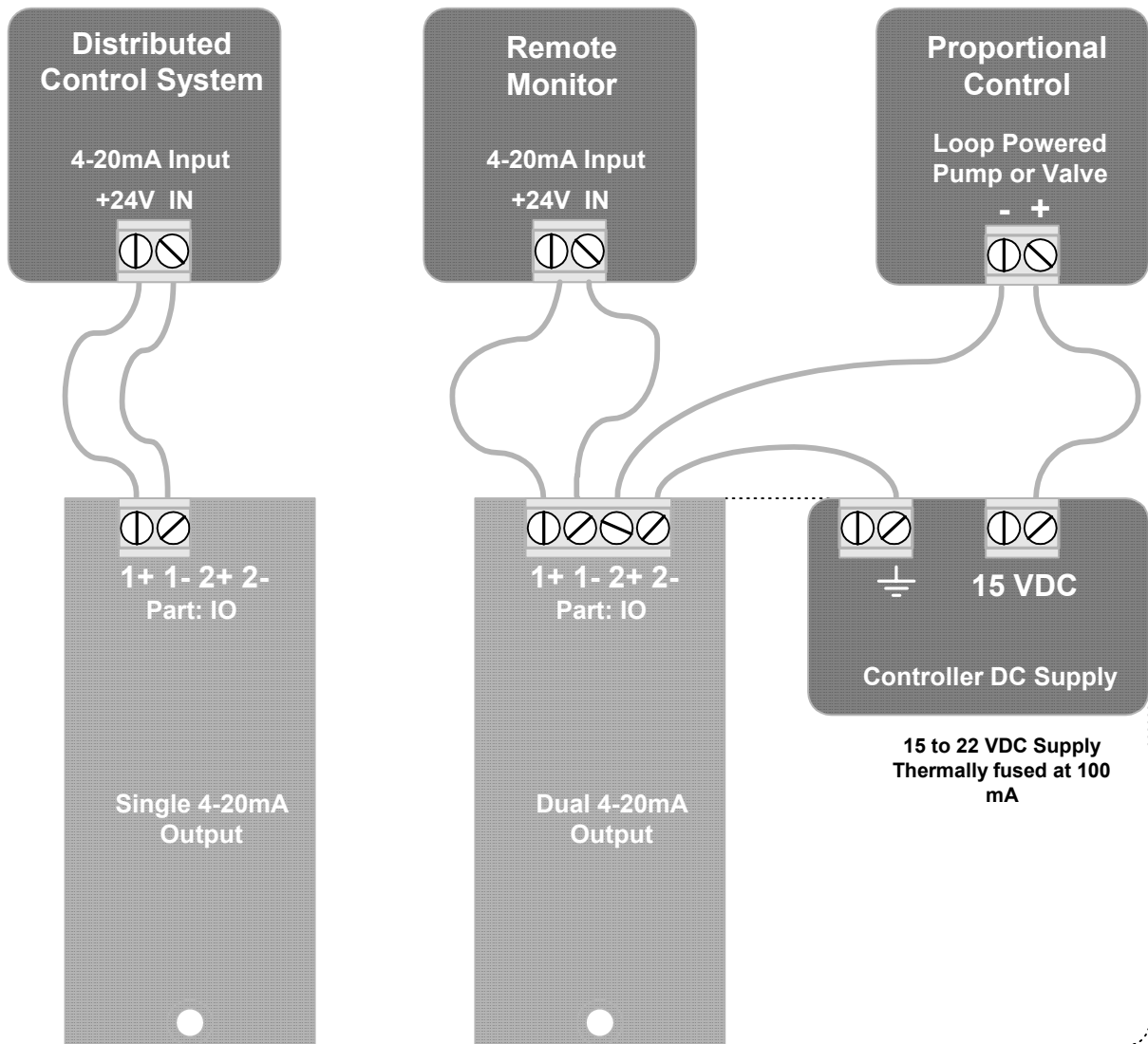

AWG22 / 0.25 mm², current loop cabling may be extended several hundred feet or meters without causing measurement errors. The maximum cable length is determined by the open loop voltage and the cable gauge.

Do not install current loop cabling in the same conduit as AC power cabling.

Current loop cabling may share a common conduit with other sensors, water meter and contact set cabling.

2. Configuration - Operation

2.1 Diagnostics

Controller Response on Driver Installation

Parameter	LCD Display	Browser	Value : Use
			C1: 4-20mA Output: LCD & Browser header Identifies the C1..C8 output assigned to the I/O driver. This output is assigned on power-on when a new IO driver is detected
Current State	OK	OK	Set to Manual 4.0mA: Defaults to 4mA and manual control when IO driver installed.
Output card @	OK	OK	G: I/O slot location: Physical location of IO driver.

Controlled 4-20mA Output

Parameter	LCD Display	Browser	Value : Use
			C1: 4-20mA Output: LCD & Browser header
Current State	OK	OK	Set to Auto: Current controlled by either a sensor or by a relay control equation.
Control by: A	OK	OK	10.6mA: Control by a sensor, letter A..N or a relay 1..10 Output current level in mA.
4mA Level	OK	OK	6.00: 4mA level in controller units. In this example; if 'A' is a pH sensor then 4mA = 6.00pH
20mA Level	OK	OK	10.00: 20mA level in controller units. In this example; if 'A' is a pH sensor then 20mA = 10.00pH
Output card @	OK	OK	G: I/O slot location: Physical location of IO driver.

2.2 Manual - Auto

A 4-20mA output may be switched from Auto control to Manual.

Manual mode allows the user to set an output from 0% to 100% to base feed, set up feed rates and verify monitoring inputs.

On return to Auto the 4-20mA span and controlling sensor or relay are restored, unchanged.

BROWSER: Controls / Configure / Select C1..C8

KEYPAD: Enter when C1..C8 displayed. Scroll to Configure & Enter

2.3 Hardware Calibration

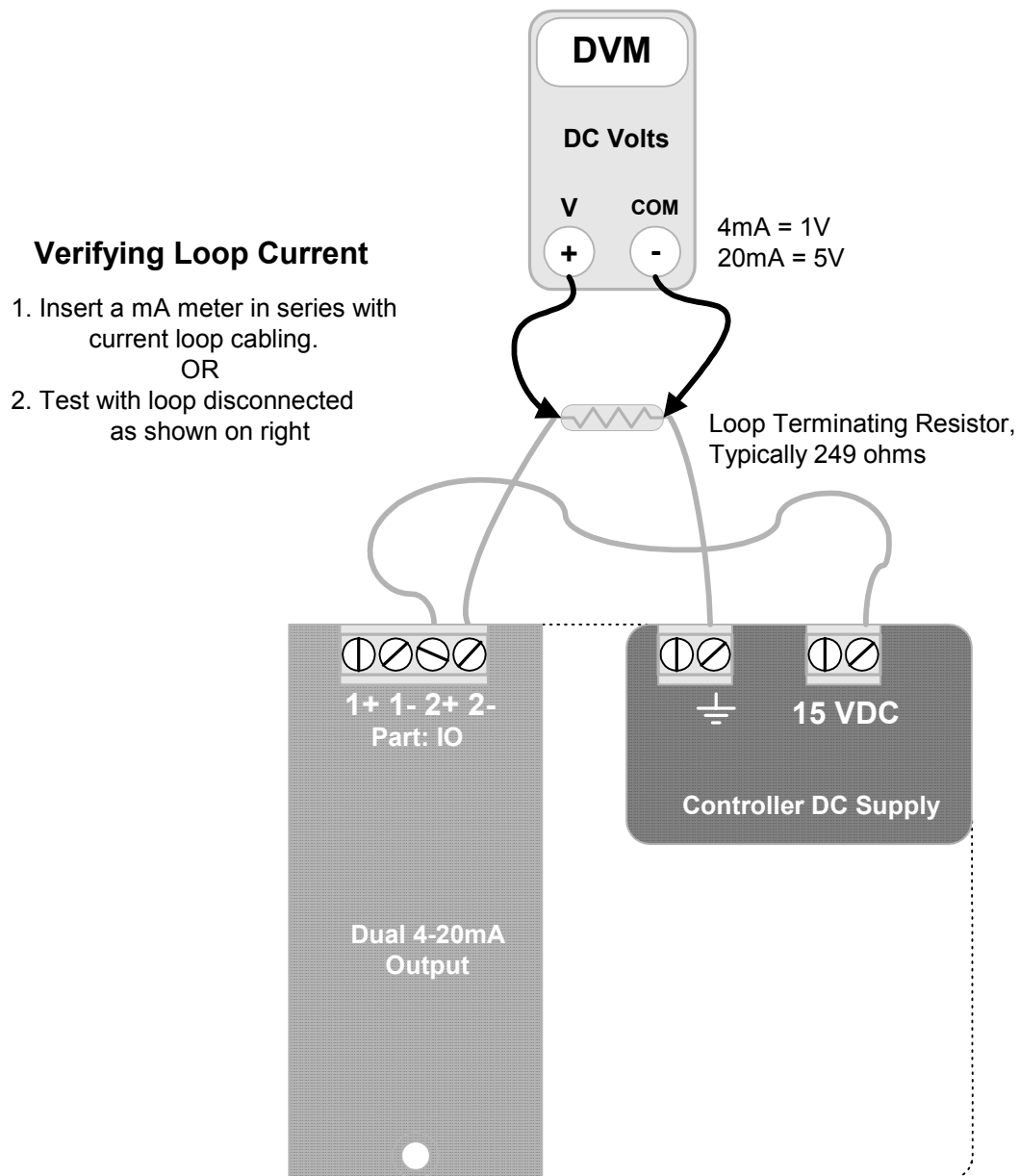

Hardware Calibration component level error from IO drivers.

It's available via the keypad and requires a current loop in Manual mode.

1. Scroll to the Target Loop C1 to C8, Key Enter, Down to Configure and Enter.
2. Key Enter at **Manual Level** and set to 0%
3. Key Down to **Trim Zero** & Enter. Key Up / Down for 4mA. 1V if the loop termination is 249 Ohms
4. Reset the **Manual Level** to 100%
5. Key Down to **Trim Span** & Enter. Key Up / Down for 20mA. 5V if the loop termination is 249 Ohms
6. The adjustment range of Trim Zero & Trim Span are limited to the values required by a functional IO Driver.

Trim Zero default = 9 Trim Span default = 950

3. Specifications

Function		Notes
Resolution & Accuracy	0.1% & +/- 0.15%	
DC Isolated	Terminals 1+ & 1- DC isolated from 2+ & 2-	Outputs DC isolated from electrical ground – controller common.
Loop Polarity	Auto-correcting	Driver input terminals are not sensitive to polarity.
Max Loop Voltage	30VDC.	Current loops powered by the controller unregulated 15VDC supply do not exceed 24VDC.
Minimum Loop Termination	10 ohms.	LMI solenoid drive pump, proportional control input = 22 ohms