

CONTENTS

1. Services

- 1.1 Application
- 1.2 Specification

2. Installation

- 2.1 Site the Sensor
- 2.2 LogR Current Loop Cabling

3. LogR Operation

- 3.1 LogR Modes
- 3.2 USB Data Log Upload

Appendix 'A' Modes



1.0 Services

1.1 Application

Components:

A corrosion rate measurement consists of 3 components:

1. An LPR (Linear Polarization Resistance) sensor installed in the cooling water or closed water loop.
2. A LogR: user interface, display, alarm, data logger and 4-20mA driver.
3. A USB 'thumb' drive used to upload the logged corrosion rate data.

Measuring General Corrosion:

General corrosion is the evenly distributed thinning of an immersed metal due to the electrochemical reaction between the metal and the process stream.

The rate of general corrosion is measured in mils per year, mpy where 1mil = 0.001".

Weight loss coupons are commonly used to measure general corrosion. The coupon is weighed, immersed for 30, 60 or 90 days, removed, cleaned & re-weighed. The loss of weight & immersion period are converted to a corrosion rate. It's an inexpensive method but it does not measure corrosion rate in real time so it's difficult to identify process conditions, which increase or decrease corrosion.

Linear Polarization Resistance (LPR) measures general corrosion rate in real time updated every 2.5 minutes. The method includes conversion approximations which result is a measured that will not be the same as the coupon rate but that will track the coupon rate.

LPR is used to measure changes in corrosion rate as process corrosivity varies and as process chemistry is controlled.

LPR Method:

LPR uses two standardized cylindrical metal coupons, nominally 0.1875" D x 1.25" L of the same metallurgy, typically both steel, copper, admiralty, copper-nickel or zinc. The coupons are polarized to several mV and the resulting current measured. The polarity is reversed & the current re-measured. The corrosion rate is calculated using the measured currents, the polarization voltage corrected for process resistivity and constants based on the coupon metallurgy.

Pitting Indicator:

The current measured when the coupon tips are connected together is displayed as a pitting index. Although LPR cannot measure the actual pitting rate, the pitting index is used as a measure of pitting severity.

1.2 Specifications

| Sensor | Specification | Explanation / Detail |
|--|--|---|
| LPR Sensor (Linear Polarization Resistance) | Non-metallic sensor rated 50C, 125F max, 125 psi max. Immersed components ABT, nylon & epoxy. | Digital, DC isolated 3 wire sensor, Power, Common & Data. Sensor supplied with ¾" SCH 80 threaded PVC 'T' fitting with ¾" non-metallic sensor entry fitting and 3m, 10ft of 3xAWG 22 PVC jacketed cable. |
| LPR_CS LPR_CU LPR_AM | 1010 Carbon Steel CDA 110 Copper CDA 443 Admiralty | 1¼"L x 3/16"D electrode set supplied installed. Sensor accepts standardized LPR electrodes threaded #4-40 UNC |

| LogR | Specification | Explanation / Detail |
|----------------------------------|--|---|
| Corrosion Rate Measure & Display | 0.01 to 50.0 mpy for steel Updates every 150 seconds. | LogR CE compliant under 89/336/EEC Electrode metallurgy user selectable. |
| 4-20mA Output | Three wire: Power, Ground & 4-20mA out Resolution nominally 1 part in 4000. | User selectable 4-20mA range from 2 to 100 mpy. Adjustable loop Span & Zero. |
| Data Logging | 1Year @ 5 minute intervals. | Log auto-uploaded via USB thumb drive in .CSV format (Comma Separated Variable) |
| Alarm Contacts | Normally closed Rated 24VDC, 250mA Thermally fused 300mA | User adjustable alarm trip point. Alarm contacts also open on loss of power. |
| Display & Data Link | 2x8 LCD Display. USB Host emulation. | Battery backed clock time & date stamps data log. |
| UP-DOWN & Mode Switches | UP & DOWN push buttons 8 Selectable display modes, 0 to 7. | 0: Corrosion 1: Metallurgy 2: Conductivity 3: Diagnostic 4: 4-20mA Current 5: Date-Time 6: Alarm Contacts 7: Loop Span |
| Conductivity | 50 to 9999 uS | Autoranging. 1uS resolution. Corrects corrosion rate for water resistivity. |
| Power | 9-24VDC, 100mA max. Polarity Protected. | Use included 12VDC, 500mA power cube or site 9-24VDC power. Power cube CUL Listed, CE approved with international plug set. |
| LogR Enclosure | Non-metallic, Rated IP65 4 3/8" x 4 3/8" x1 ¾", 110mm x 110mm x45mm | PG16 cable entry for sensor & current loop cabling included. Wall mount 3-point bracket included. |
| Wiring Terminal Blocks | Rated AWG16-26 3.5mm spacing. | Power, 4-20mA, sensor and alarm contacts, 2 piece, removable wiring blocks |

2.0 Installation

2.1 Site the Sensor

Typical: Install in the supplied 3/4" PVC 'T' in the piping sensor header used for water treatment conductivity, pH & ORP sensors, upstream of the point of chemical addition. The sensor header is typically fed from the outlet of the recirculating pump and returns to the inlet side of the pump. Inlet and outlet isolation valves allow servicing of the sensor set.

Worst Case: Install immediately downstream of the hottest water, typically on the outlet side of the exchanger.

High Pressure: Install downstream of a PRV (pressure regulating valve) in a 3/4" drop leg to ensure continuous immersion & pipe to drain. If water usage a concern, use a timer to refresh the sample line.

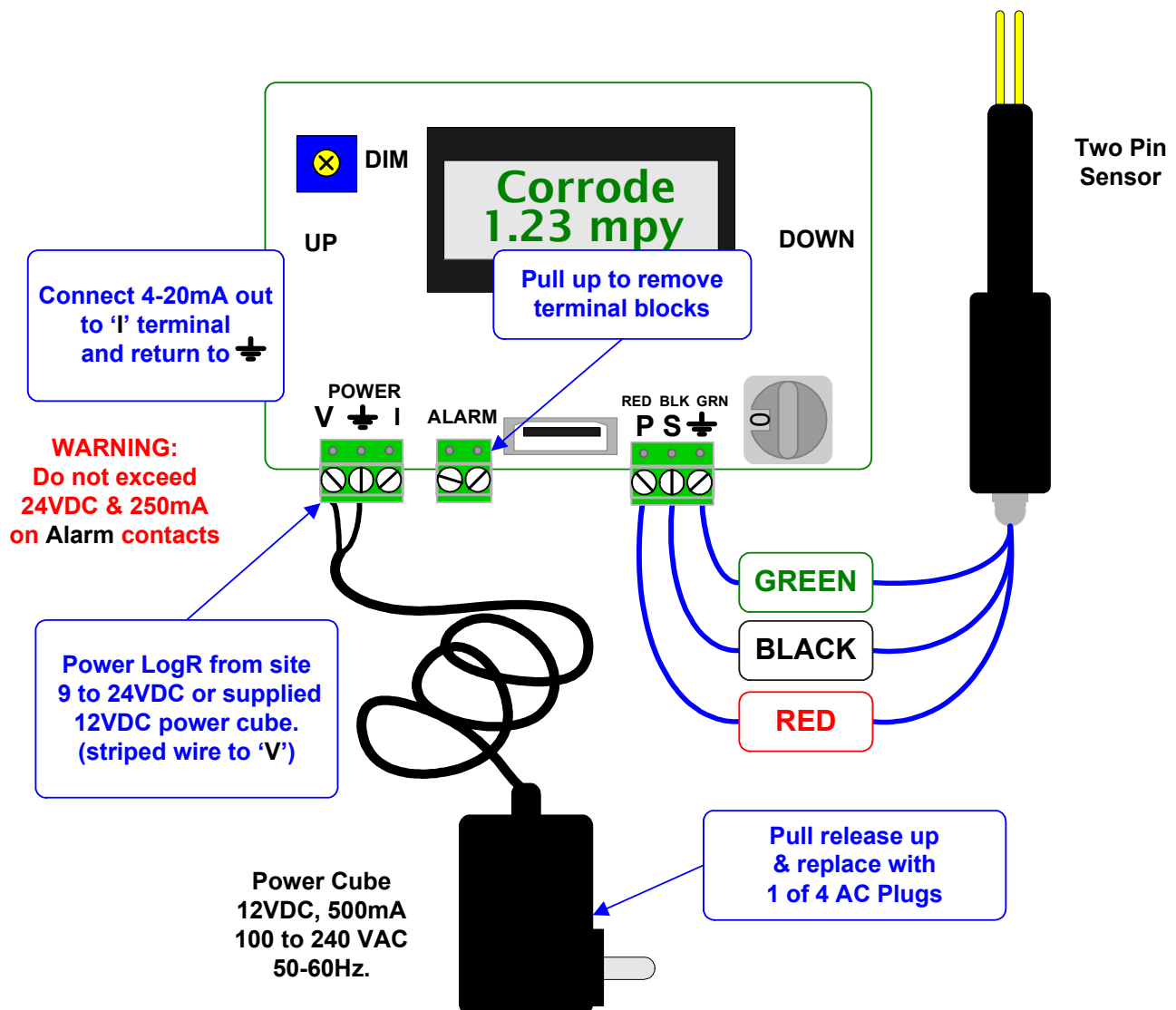

2.2 Current Loop Cabling

Use the 12VDC power supply included with the LogR or the site 9-24VDC to power the LogR.

The included power supply is a wall socket plug-in type with 4 interchangeable plug connectors

The LogR blocks incorrect DC wiring polarity.

The corrosion rate sensor is DC isolated so where the loop power supply is grounded or not-grounded and how the loop is terminated, has no effect on the operation of the sensor.

Do not exceed a 250 Ohm loop terminating resistor if using a 9VDC supply.

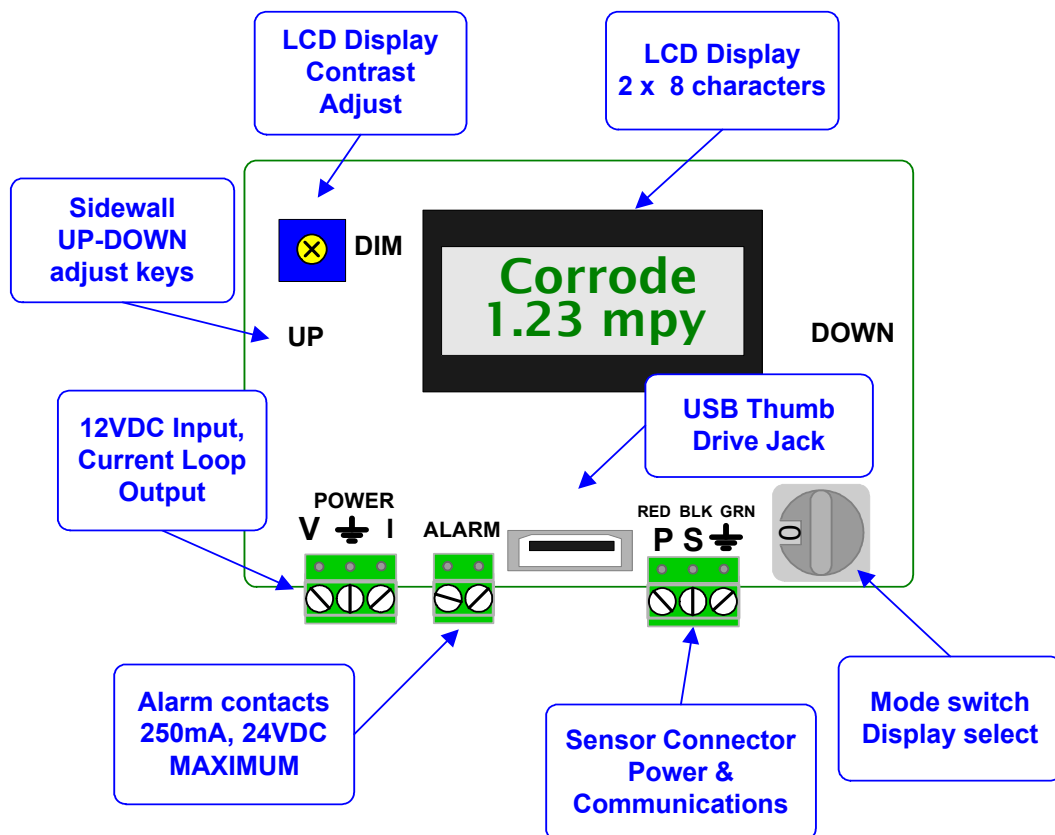

3.0 LogR Operation

3.1 LogR Modes

The Mode switch selects the LCD display.

If you adjust the LogR using the sidewall UP & DOWN keys, the change is saved to the LogR flash when you select the next Mode.

Most users will leave the LogR in **Mode 0**, displaying the Corrosion Rate level & updating every 150 seconds.

Displays 2 digits after the decimal @ corrosion rates less than 10 mpy (mils per year, 1mil = 0001")

'**No Sensor**' will display if the sensor is disconnected & will auto-correct on sensor re-connection.

On power up this Mode 0 counts down 150 seconds to the first corrosion rate reading.

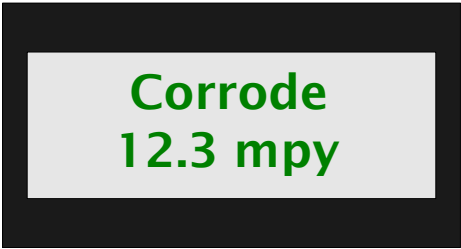

Mode 0, Corrosion Rate

1. Updates every 2.5 minutes.
2. 'No Sensor' on sensor disconnect.



UP

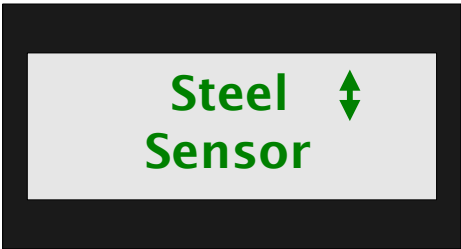

DOWN

Mode 1, Sensor Type

1. Press UP or DOWN after changing sensor tip metallurgy.
2. **UP** or **DOWN** to select. Saved on next **Mode** selection.



The LogR is set for the tip metallurgy ordered with the LogR. If you change the tip metallurgy, use Mode 1 to select the tip metal or alloy.

The **UP** & **DOWN** keys are located in the upper conduit entries on the enclosure sidewalls. You'll feel a click on press.

Steel, Copper, Admiralty, 90:10 Cupro-Nickel and Zinc (galvanizing) sensor tips are selectable.

When you change the sensor type, the next corrosion rate measurement and subsequent logged values reflect the new metallurgy.

3.1 LogR Modes continued

Conductivity compensates the measured corrosion rate for the error due to water resistivity.

Below about 200uS (varies with corrosion rate & tip metallurgy) LPR measurement is not possible. Warning appears on **Mode 0** display.

Displays >9999 over 10,000uS.



2

Mode 2, Conductivity

1. Corrects measured corrosion rate for water resistivity.





3

UP
DOWN

Mode 3, Diagnostic

1. Time to next measure.
2. Press UP or DOWN to view parameters.
3. Access to erase log option



Update@ counts down to next corrosion rate measurement.

UP or **DOWN** press displays:
Anodic 123 mV
Cathodic 456mV
Pitting 11
LogSize 14682

A higher **Pitting** index indicates localized corrosion likely.

Press **UP & DOWN** to erase Log.

The current loop is scaled
 4-20mA = 0 to 100% Filming.

Loop current may be adjusted using the **UP & DOWN** keys on the enclosure sidewalls.

Disconnect the sensor to adjust the 4mA, loop zero.

Loop adjustment is saved when **Mode 4** is switched to another selection.

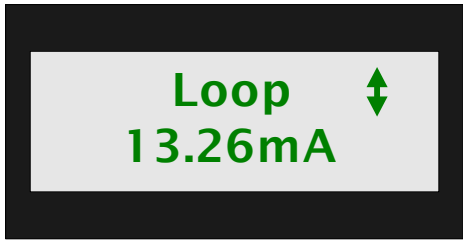

4

UP
DOWN

Mode 4, 4-20mA Loop Current

1. Spanned 0 to 100% Filming.
2. **UP** or **DOWN** to adjust span.
3. Disconnect sensor to adjust the 4mA, loop zero.

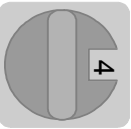

3.1 LogR Modes continued

The date & time displayed by **Mode 5** are used as the Date -Time stamp for logged data.

Adjusting Date & Time does not modify the Date-Time stamp on previously logged corrosion rate data sets.

Switching **Mode** without pressing **UP** & **DOWN** leaves the Time Date unchanged.

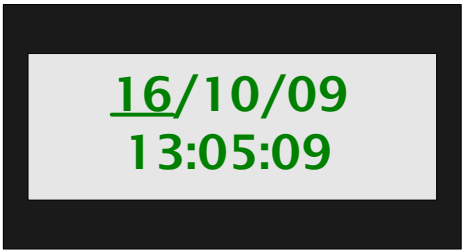

5

Mode 5, LogR Date & Time, Adjust Clock

1. DD/MM/YY & HH:MM:SS 24 hour clock.
2. UP moves underline. DOWN to adjust
3. Press UP & DOWN to save changes.



UP



6

DOWN

Mode 6, Contact Set Alarm Trip Point

1. Press UP or DOWN to adjust trip.
2. Saved when **MODE** changed.
3. Alarm contact set opens on alarm.



A measured corrosion rate above the **Alarm@** level, opens the alarm contact set.

Removing power from the LogR, opens the alarm contact set.

Warning: Alarm contact set rated 24VDC & 250mA, thermally fused @ 300mA. Do not use to switch AC line voltages.

Mode 7 displays the current 4-20mA corrosion rate scaling.

Use this value to scale the monitoring end of the 4-20mA current loop.

UP

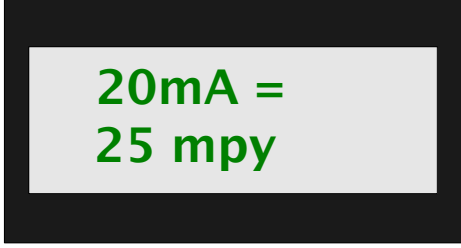

7

DOWN

Mode 7, 4-20mA Loop Span

1. Press UP or DOWN to set 4-20 current loop range.
2. Saved when **MODE** changed



3.2 USB Data Log Upload

Remove the LogR cover by inserting a screwdriver tip into one of the leverage sockets located on each corner of the cover.

Insert the USB 'thumb' drive supplied with the LogR into the USB 'A' socket.

The LogR supports any SCSI compliant thumb drive, the format used by most drives. If you insert a non-compliant drive, it will not be detected.

The **USB Drive detected** message displays on all Mode switch settings & disables Mode switch **UP** & **DOWN** and selection functions.

Displays **Log Upload** and counts down to completion.

Remove the USB thumb drive on **Remove Drive** message & replace the LogR cover. Press firmly to ensure a weatherproof cover seal.

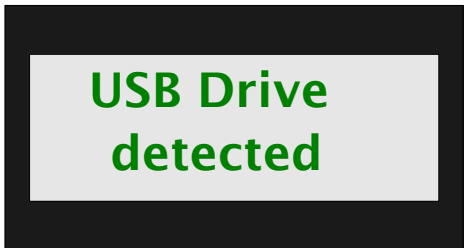

**USB Drive
detected**

0-7

Mode 0..7 USB Log Upload Status

1. All modes display USB status while USB thumb drive installed.
2. **'Remove Drive'** displayed on upload complete.



Log File Name:

The log file appears on the thumb drive as **L[last 4 digits of Serial#]C[DDMY].csv**

A typical file name would be **L1234C16B0.csv**

Where 'C' designate 'Corrosion Rate', DD is day of month 1 to 31, M is month 1 to C & Y is last digit of year 0 to 9.

If you upload more than once in any one day, only the most recent log is saved on the thumb drive.

The LogR serial# is included for users with multiple LogR's and the 'C' designator differentiates LogR files from other sensor types.

Excel Import:

Comma separated variable, 'csv' file can be read and displayed by excel.

Appendix 'A' Modes

| LogR Menu Mode switch 0 to 7 | Displays | UP/DOWN Scroll |
|---|--|--|
| 0: Corrosion Rate | Corrode 0.01 mpy Corrode 50.0 mpy (See Note 0.) | Displays measurement state Measure OK or Low uS Limit or High Pitting Updated every 150 seconds, 2 ½ minutes |
| 1: Sensor Type | Steel Sensor Copper Sensor Admrlty Sensor CuNi Sensor Zinc Sensor | Selects sensor electrode metallurgy. Changing Mode with new metallurgy selected changes corrosion rate measurement. |
| 2: Conductivity | Conduct 50 uS Conduct 2000 uS Conduct >2000 uS (See Note 2.) | No UP/DOWN response |
| 3: Diagnostic | Update@ 126 sec Anodic 123mV Cathodic 106mV Pitting 12.6 LogSize 14682** (See Note 3). | Selects diagnostic display **Press UP & DOWN at the same time to clear log, LogSize 0 |
| 4: Loop Current | Loop 16.74mA Loop 4.00 mA | Adjust 4-20mA loop span if not at 4.00mA. Adjust 4-20mA loop zero if at 4.00mA. Disconnect the sensor for 4.00mA |
| 5: Time & Date | 28/09/10 13:29:08 | UP moves the underline cursor right DOWN changes the underlined value Pressing UP & DOWN at the same time saves your Time-Date changes. |
| 6: Alarm Contacts | Alarm@ 12mpy Alarmed! >12mpy | Adjusts the corrosion rate that opens the alarm contact set OR displays an active alarm |
| 7: Loop Span | 20mA = 20 mpy 20mA = 2mpy 20mA = 100 mpy | Adjusts the mpy value at 20mA, the 4-20mA loop span. 2 mpy loop span minimum 100 mpy loop span minimum |
| 0-7: Log Upload User inserts USB thumb drive | USB Drive detected Log Upload 12 sec Remove Drive or Upload Fails | Overrides display when thumb drive inserted. Auto uploads current log onto USB drive. Counts down log upload time remaining 'Remove' on success or error message on incompatible drive, drive full, write protected drive ... |